

Saponification Stressing the Newer Methods

LEO D. JONES, The Sharples Corporation, Philadelphia, Pennsylvania

THIS DISCUSSION will be limited to the saponification of fatty glycerides with aqueous sodium hydroxide solutions. Fundamental and theoretical considerations of the saponification reaction will first be discussed, then the various commercial practices now in use will be described.



Leo D. Jones

In saponification, glyceride fats are reacted with sodium hydroxide to form soap, that is, the sodium salts of the fatty acids contained in the glyceride and glycerol.

The Kinetics of Saponification

Fats and aqueous caustic soda solutions are substantially insoluble in each other. They can only react with each other at the surface between the aqueous and fatty phases. With commonly used fats which are highly refined and neutralized such as tallow or coconut oil, this reaction is very slow; neutral tallow

may be boiled for hours with a 10% aqueous caustic solution without visible evidence of reaction. The rate of reaction, since it is a surface one, is proportional to the amount of surface and can be greatly increased by any mechanism which accelerates the dispersion of the aqueous solution in the fat, such as violent agitation or passage through a colloid mill.

After an appreciable amount of soap has been formed, the soap dissolves a substantial amount of the fats and caustic soda, and the reaction becomes a homogeneous one since both reacting components are in the same phase. Reaction then proceeds at a rate many times that at which the reaction occurred during the initial stages when the reaction was a heterogeneous one, with reacting components in different phases.

Assuming that the fats and caustic soda are present in the relative proportions in which they enter into the reaction, the saponification reaches a maximum rate when about half of the fat has been saponified. As the reaction proceeds, the concentration of fat and caustic soda is reduced, and the reaction slows up more and more as this concentration is reduced.

A typical curve showing the proportion of fat saponified against time is shown in Figure 1. The lower portion of this curve, when the reaction is primarily a heterogeneous one occurring at the surface between the phases, is referred to as the induction period.

Definite figures for the time of reaction are not given because the rates are influenced to such a high degree by indeterminable variations in the fats and by physical conditions which are difficult to determine or to reproduce.

Because of the difficulty of starting the reaction, it is common practice to start with an aqueous solution of soap and to add progressively fats and caustic

soda solution. Saponification can be started well up on the curve, for instance, at the point marked S, and the time-consuming induction period can be avoided entirely. If the fats used are not neutral, the free fatty acid immediately reacts with caustic soda, forming soap, and the beginning of the induction period is cut off to the extent that fatty acids are present.

The rapid increase in rate as the saponification reaction proceeds can be disastrous if not understood and controlled. In a kettle charged with neutral fats, for instance, a reaction which is very slow in starting may, after the kettle has been well filled with fat and caustic soda solution, suddenly pass to the middle portion of the curve with rapid reaction, substantial liberation of heat, and a boiling over of the kettle. The reader is referred to "The Kinetics of Soap Making" by E. Lester Smith (1) for a more detailed presentation of the subject.

Phases Occurring in Saponification

A great deal of research work has been done on the physical state of mixtures of soap, water, and glycerine and of caustic soda and sodium chloride, that is, salt. The last two substances are commonly referred to collectively in the soap industry as electrolytes. A typical phase diagram of these components is shown in Figure 2 (2). Glycerine is considered to be equivalent to water and salt equivalent to caustic soda. Three component phase diagrams are usually drawn as equilateral triangles, but since in this study only a small proportion of the total triangle is of interest, only a small portion of a right angle triangle is used. 100% soap is at the apex of the triangle, 100% water (or glycerine) is at the lower left right angle, and 100% salt is at the right-hand corner of the triangle which does not appear in the diagram. Areas corresponding to the various phases met with in mixtures of soap, water, and salt are outlined.

The presence of fat during the saponification reaction does not change the phase relationships of water, salt, and soap already formed to a substantial degree. The fat remains as a separate phase or dissolves partly in the soap phase, accordingly this phase rela-

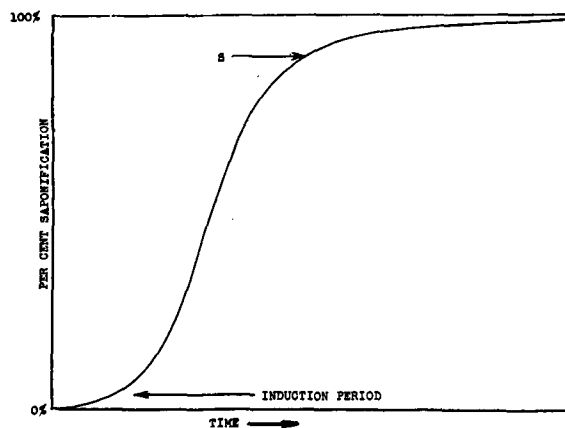

FIG. 1. Typical curve: time vs. saponification.

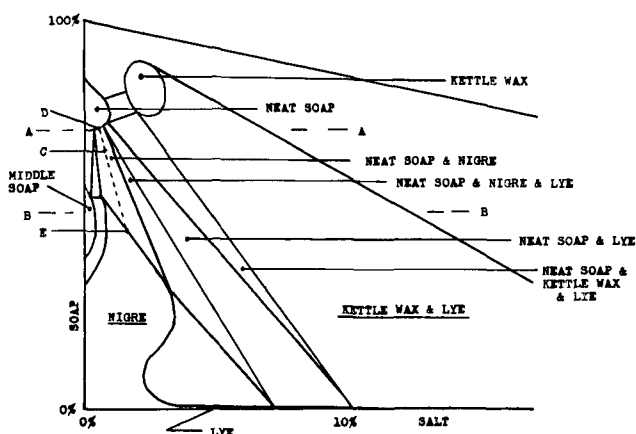

FIG. 2. Typical phase diagram: soap, water, and salt.

tionship is of importance in the study of the physical conditions during saponification.

In commercial saponification the relative proportions of soap and water usually lie between the lines AA and BB. The phases present in the mixture are then largely dependent upon the concentration of electrolyte. If that concentration brings the total composition into the area marked neat soap plus nigre, there will be present in the mass both neat soap and nigre phases. Thus if the composition is at the point marked C, the mixture will split along the line passing through C to form a neat soap phase of the composition of point D and a nigre phase of the composition of point E, and the proportions of neat soap to nigre will be inversely proportioned to the distances CD and CE.

This area, neat soap plus nigre, is commonly considered the best area for the rapid propagation of the saponification reaction. The neat soap phase, which contains about 70% soap, is a good solvent for any unsaponified fat, also for caustic soda in limited quantities.

If more electrolyte is present, placing the total composition of the reacting mixture in the area marked neat soap and lye, there will be present the phases neat soap and lye. It has generally been considered in the soap industry that reaction proceeds rather slowly under these conditions, but more advanced kettle practice and several of the continuous processes in commercial operation have shown that the rate of saponification is sufficiently rapid for practical purposes. There are economic advantages which offset the reduced rate. Soap in contact with either nigre or lye is in the neat soap phase and dissolves caustic soda and fats and catalyzes the reaction. In the presence of excessive amounts of electrolyte, which bring the total composition of the saponification mixture into the kettle wax plus lye area, saponification may be greatly retarded and a soap phase formed which is difficult to separate by gravity or centrifuge.

Along the left-hand side of the triangle is an area marked middle soap. This phase is one which the soap-maker should carefully avoid. The soap in this phase has physical properties which inhibit its conversion back to more useful phases; when through mismanagement of saponification it occurs in a kettle, dissolving it is a time-consuming operation. It can be avoided by limiting the amount of water present so that the composition of the mass is above the mid-

dle soap area or by insuring enough electrolyte to keep to the right of the middle soap area.

Kettle Practice

Various techniques are used in the saponification in a kettle, but discussion will be limited to one which has been found satisfactory.

In the last stages of soap-making in the kettle the mass is boiled up and brought to a composition approximately that shown by c in Figure 2. This condition is referred to as the finish. The mass separates into neat soap and nigre and is allowed to settle for several days. The supernatant neat soap is skimmed off, and the lower nigre is allowed to remain. Commonly referred to as a nigre bottoms, this is used as the initial charge for a new saponification. The soap contained in the nigre acts as a catalyst for the ensuing saponification. The nigre bottoms is brought to a boil; fat and caustic are continuously added in the correct proportions for the reaction.

It is well to add the fat and caustic soda solution at such a rate that the mass is 90% or more saponified at all times. It is also well to maintain enough excess caustic soda to insure that the mixture will be in the neat soap and nigre area. As the supply of fat runs low, the addition of caustic is reduced. To maintain the required electrolyte concentration so as to avoid middle soap, salt may be added; and as the final fat is added, the addition of caustic soda solution is so controlled as to end up with a substantially neutral mass.

Sufficient salt is added to the kettle to precipitate or grain out all of the soap, leaving the aqueous phase as a lye substantially soap-free instead of as a nigre. The kettle is then allowed to settle, the lye or glycerine water is drawn off, and the mass in the soap kettle is processed further to wash out glycerine.

Completely to salt out the soap from the aqueous phase must be done with some discrimination. Just enough salt to complete the precipitation will give the most rapid rate of settling and a grained soap mass containing the least entrained aqueous phase. Greater amounts of salt cause the formation of kettle wax, which settles less readily and occludes a greater proportion of the aqueous phase.

If the fats are acid, which is usually the case in practice, the saponification proceeds rapidly without the use of a nigre bottoms to start. With neutral fats a small proportion of the charge must be well saponified before proceeding to fill the kettle with fats.

Continuous Saponification Processes

Continuous saponification processes became important commercially about 10 years ago, and four of these are currently in use in a number of soap plants. These are the Mon Savon (3), the Unilever (4), the Sharples (5), and the De Laval (6, 7). All of these processes follow the saponification with washing in salt solution to recover glycerine. The first two use gravity settling and the latter two, centrifuges for the separations in the washing stages.

The Mon Savon Process

The saponification step of the Mon Savon process is shown in Figure 3. Fat and caustic soda solutions are metered by variable stroke piston pumps 1 and 2 continuously into a colloid mill. The finely dispersed

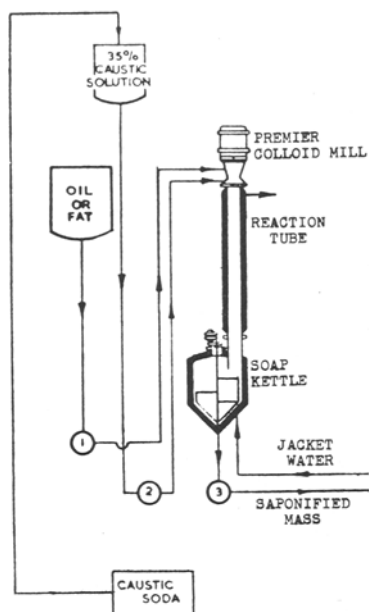

Fig. 3. Saponification step of Mon Savon process.

mixture flows down through the reaction tube without further agitation into the soap kettle, where very mild agitation is maintained and the saponified mixture is pumped from the bottom of the soap kettle by metering pump 3 and then passes to the washing stages of the process.

The concentration of the caustic soda solution is adjusted so that the mixture will have a composition substantially equivalent to that of the point D in Figure 2. In other words, the soap mass is in the neat soap phase.

The ratio of fat and caustic soda fed to the colloid mill must be accurately controlled to have a sufficient amount of caustic soda in the mixture to have sufficiently saponified the fat and at the same time not be of such an excess as to result in an uneconomical waste of caustic soda. There is no mechanism for the utilization of any excess caustic soda in the spent lye. Complete saponification is obtained if approximately an excess of 4% of caustic soda is used.

The intimate contact provided in the colloid mill reduces to a short time the induction period whereas the mild agitation occurring in the streamlined flow through the reaction tube and in the soap kettle are sufficient to continue the reaction after enough soap has been formed to act as a catalyst. The reaction tube and the soap kettle have a cubicle content sufficient to provide for a retention time of approximately an hour.

All of the heat of the reaction, including that of diluting the caustic soda with the liberated glycerine, remains in the reaction mass so that if the fat is fed to the colloid mill at approximately 160°F., the completely reacted soap mass will have a temperature between 200 and 220°F.

The reaction tube and soap kettle are jacketed, and hot water is circulated through the jackets so that their contents may be maintained hot and fluid if flow of fat and caustic are discontinued for a time.

The Unilever Process

The saponification process developed by R. V. Owen of Unilever Ltd. is very similar in principle to the

Mon Savon process but differs in the mechanism. A detail of the emulsifier is shown in Figure 4, and the layout of the process in Figure 5.

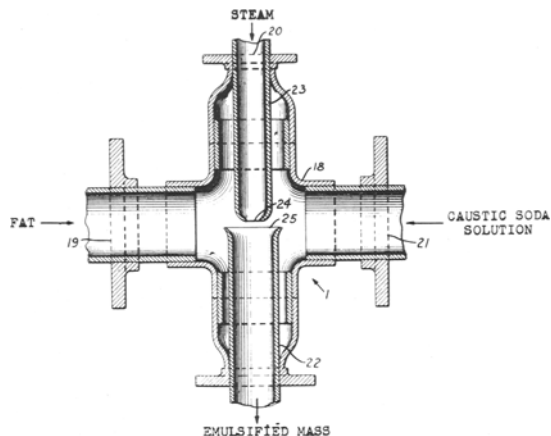

Fig. 4. Emulsifier of Unilever process.

The fat and caustic soda solutions (Figure 4) are metered into side inlets of the emulsifier in the correct proportions, and steam is introduced into the top of the emulsifier to provide the energy for emulsification and partial heating. The emulsified mass discharges from the bottom.

The emulsifier is shown at 1 (Figure 5), and the

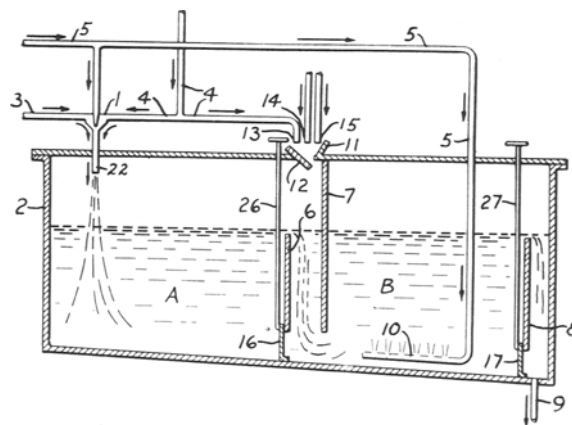

Fig. 5. Saponification chambers of Unilever process.

emulsified mass flows into an aging chamber, A, where the only agitation is the mild rate of flow through this chamber and over the weir 6 into chamber B. Additional salt or caustic soda solution may be added at the point where the mixture flows over the weir into chamber B; the mixture may be mildly agitated and heated by steam from the perforated coil 10. The saponified mass finally overflows the weir 8 to the washing stages of the process. Mr. Owen suggests that a retention time in each of chamber A and chamber B of 20 min. is sufficient for completion of the reaction.

The only basic difference between the Mon Savon process and the Unilever process is the difference between a colloid mill and a steam jet for emulsification. High dispersion is used to start the reaction and mild

agitation for its completion. Mr. Owen indicates that different concentrations of caustic soda should be used, depending upon the fats to be saponified; the choice is that which gives an emulsion best suited for a rapid reaction.

The Sharples Process

The Sharples process differs from these two processes in providing two countercurrent stages for the saponification. In the first stage there is an excess of fat for the complete utilization of the caustic soda in the spent lye leaving the process. In the second stage there is an excess of caustic soda to insure complete saponification of all of the saponifiable constituents of the fat, and the lye separated from this second stage which still contains caustic soda is used in the first stage. By the use of the two-stage countercurrent system there is greater assurance of using up all of the caustic and of completing the saponification without such exact requirements for the proportioning of fat and caustic soda.

In the first two processes the saponification reaction follows the curve shown in Figure 1; the induction period is speeded up by the use of devices for creating a fine dispersion. In the Sharples process (Figure 6)

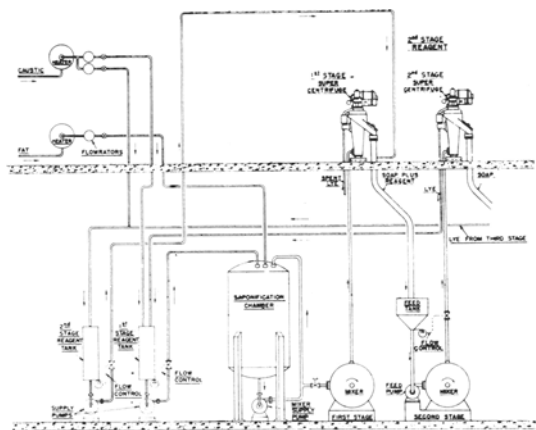

FIG. 6. Saponification stages of Sharples process.

the induction period is avoided entirely; along with it the need for high dispersion is eliminated. The saponification reaction occurs in a mass maintained constantly at approximately the point S on the curve in Figure 1. There is present mainly soap to act as a catalyst for the reaction; with comparatively mild agitation rapid saponification occurs.

The saponification chamber is mildly agitated by drawing the mixture off of the bottom and returning it by centrifugal pump to the top. Lye containing salt which has been used to grain out the soap in the second stage and some caustic soda from the excess used to complete saponification in the second stage and fresh 50% caustic soda solution are continuously fed into the top of the saponification chamber. Fat is also fed continuously. The mixture is withdrawn from the discharge of the centrifugal pump at the same rate at which new materials have been supplied. The physical and chemical characteristics remain constant with the passage of time, the fat is from 90 to 98% saponified, and the mixture has a composition in the neat soap lye area. As a control, a sample of the

contents of the chamber is withdrawn from time to time, the aqueous phase is separated by gravity, which takes but a few minutes, and is titrated for its caustic content. This is maintained at approximately 0.4%. Variations are corrected by reducing or increasing the rate at which caustic soda is supplied to the process.

The mixture withdrawn from the saponification chamber passes to the first stage mixer, where the excess of fat reacts with the residual caustic soda so that as the mixture leaves the mixer, the concentration of caustic in the lye is under 0.1%. The mixture is separated in the first-stage centrifuge into spent lye and into soap. As the soap is discharged from the centrifuge, it is mixed with the second-stage reagent, consisting of lye separated in the third stage, flowing countercurrently into the second stage and containing salt and caustic soda. Enough fresh caustic is added to saponify any fat not saponified in the first stage. This mixture of soap from the first-stage centrifuge and second-stage reagent passes through a second-stage mixer in which the excess of caustic soda present completes the saponification of any residual fat. The mixture from the second stage mixer is separated in the second-stage centrifuge; the lye is returned to the saponification chamber, and the soap is completely saponified, passing on to the washing stages.

While the saponification in the chamber occurs with the soap in the grained state, in which the reaction is somewhat slower than in the so-called closed state, this loss of reaction speed is more than made up by the elimination of the induction period and the assurance that there is ample soap to act as a catalyst whether the fat charged to the process contains some fatty acid or is completely neutral.

The De Laval Process

The saponification steps of the De Laval continuous soap process are shown in Figure 7. An almost completely saponified mass, acting as a catalyzing agent for saponification, is continuously circulated by pump 3 through the saponification chamber 1 and the return pipe 2. Fresh caustic soda solution is continuously metered into the return pipe 2 so that the bottom of chamber 1 contains an excess of strong caustic soda. Fat is continuously metered into compartment b of chamber 1, where it is dispersed into the circulating soap-caustic soda mass. To increase the contact between the fresh fat and the soap-caustic soda mixture, a secondary circulating pump 4 withdraws mixture from compartments a and b of chamber 1 and returns it to compartment b. A soap mass, 99.8% saponified, continuously flows from the top of chamber 1 into the secondary chamber 5. In this chamber further saponification occurs so that the mass leaving the top of chamber 5 is at least 99.95% saponified. This passes on to the subsequent stages of washing and fitting.

The electrolyte content of the soap mass is controlled automatically by the De Laval constant-composition system. This control system is based on the physical changes in viscosity which occur in the soap mass at various electrolyte contents. At low electrolyte content the soap mass is extremely viscous. As the electrolyte content increases, the viscosity rapidly decreases to a minimum point. Increase in the electrolyte content past its minimum point again will show a rise in viscosity. Figure 8 shows some of

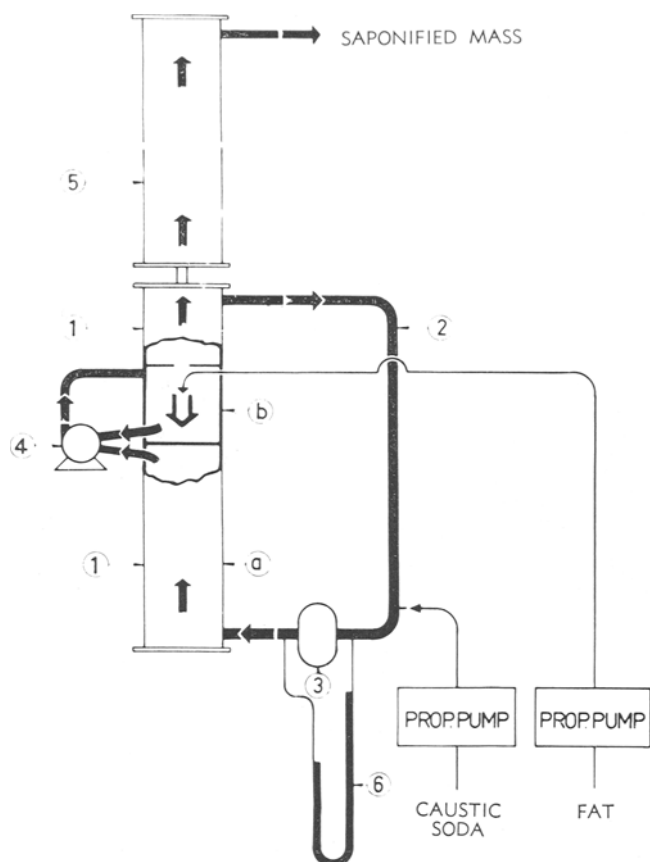

Fig. 7. Saponification steps of De Laval process.

these characteristic viscosity-electrolyte curves in connection with a typical McBain diagram. By measuring the change in viscosity by a differential pressure manometer 6 and in turn transmitting this pressure differential through pneumatic control and proportioning pumps, the electrolyte content of the soap mass is controlled automatically. If desired, the excess of electrolyte may be controlled within \pm or -0.01% .

Comparison of Continuous Processes

The Mon Savon process and the Unilever process both use high dispersion of fresh mixtures of fat and caustic soda for the purpose of reducing time of the induction period and then use mild agitation for the completion of the reaction.

The Sharples and De Laval processes both carry on saponification in a circulating soap mass, avoiding the induction period.

The Mon Savon, Unilever, and De Laval processes use only one stage of saponification. An excess of caustic must exist at the exit to insure complete saponification, and a further excess must be used to allow for random variations in the performance of the metering devices. Experience has shown that an excess of approximately 4% of the total amount of caustic soda required for saponification must be used in a single-stage process. The use of two stages in the Sharples process insures complete saponification of

the fat in the presence of an excess of caustic and a substantially complete utilization of the caustic soda in the presence of an excess of fat. This saving of reagent in the two-stage process is attained at a higher capital cost of a two-stage process over a one-stage process.

In the Mon Savon, the Sharples, and the De Laval processes no heat is added to the system except the heat in the fat and caustic as they enter the system. The caustic is normally added at room temperature, and the final temperature is dependent entirely upon the temperature at which the fat is introduced into the process, the heat of saponification, and the heat of dilution of the caustic soda. The three processes are a stand-off in this respect. The temperature conditions in the Unilever process are not as clear

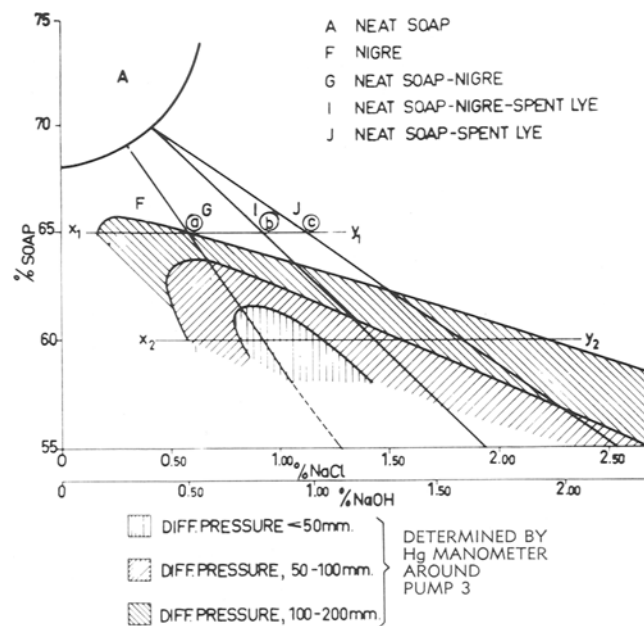

Fig. 8. Viscosity-electrolyte curves.

since the emulsification is carried out by a steam jet, some of the steam from which is condensed and some passes off uncondensed. However all of the heat of saponification and dilution of the caustic is available. In contrast, the contents of a kettle must be substantially at the boiling point for the steam to provide agitation, as otherwise it would condense without agitating. Accordingly some of the heat of reaction may be lost in maintaining the saponification mass at a boiling temperature. Also to the extent that the steam passes through the kettle uncondensed, it is lost as a supply of heat.

REFERENCES

1. J. Soc. Chemical Ind., Oct. 7, 1932.
2. Ind. Eng. Chem., vol. 35, No. 8.
3. LaChamp and Seemuller, "Un procédé français continu de saponification," Ind. des Corps Gras, Jan. and Feb., 1947.
4. U. S. Patent 2,566,359 (Unilever).
5. Smith, Julian C., "Centrifugal Separation Permits Continuous Production of Soap," Chemical Industries, Nov., 1948.
6. Indian Patent 47428, June 5, 1952.
7. U. S. Patent, 2,727,915 (De Laval).